

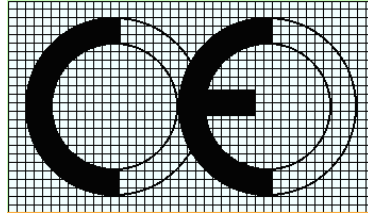

Robinson
Concrete



2025

DECLARATION OF PERFORMANCE (DOP)

Category 1 Aggregate Concrete Masonry Units No. MU009

1. Unique identification of Product type:

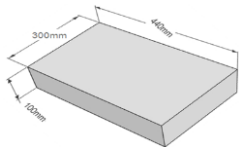
Description	Mean Strength N/mm ²	Dimensions (Length – Width- Height) mm		
		Length	Width	Height
18 x 12" Foundation Blocks	13N/mm ² (Capped) 	440	300	100

2. **Type batch or serial number or any other element allowing identification of the construction product as required under Article 11 (4) of the CPR:**

The production details are traceable by the delivery note.

3. **Intended use/s:**

IS EN 771-3 2011 & BS EN 771-3 2011 – Aggregate Concrete Masonry Units intended for use in load bearing or non-load bearing buildings and civil engineering end uses

4. **Manufacturer:**

Robinson Concrete, 86 Cumber Road, Claudy , Co Londonderry BT47 4JA.

5. **Authorized representative:**

Mr. Scott Robinson

6. **System of AVCP:**

System 2+

7. **Harmonized standard:**

EN 771-3 Specification for Masonry units Part 3: Aggregate Concrete Masonry Units (Dense & Lightweight aggregates)

8. **Notification certification body:**

NSAI

9. Declared performance:

Essential characteristics	Declared Performance	Technical Reference
Dimensional Tolerance	D1	SR325
Configuration	Group 1	SR325
Gross Density (Direct Airborne Sound Insulation)	2050 kg/m ³	EN 772-13
Compressive Strength (Mean)	13 N/mm ² (Capped)	EN 772-1 & SR325
Unit Category	Category 1	Table 14 SR325
Direction of Load	Perpendicular to bed faces	
Dimensional Stability – Moisture Movement	<0.6mm/m	EN 772-14
Reaction To Fire	Class A1	Technical Guidance Document B-Fire Safety
Durability Against Freeze Thaw	Suitable for use in: Masonry Condition Situations A1,A2 & A3 as outlined in Table 14 of S.R. 325:2013 + A2:2018. (Work below or near external ground level) - MX2. 1/2.2 -Mean compressive strength ≥ 13 N/mm ² -Aggregate in accordance with I.S. EN 12620 and S.R 16 -Mortar Strength Class M4 for A1, M6 for A2 & M12 for A3	SR325
Shear Bond Strength	0,15N/mm ²	(Tabulated Value)
Flexural Bond Strength	0,5N/ mm ²	(Tabulated Value)
Water Absorption	<10g/m ² s	EN 772-11
Water Vapour Permeability	5/15u	EN 1745 Annex A (Tabulated Value)
Thermal Resistance	1.11 W/mK _(,10, dry,)	(Tabulated Value)
*Dangerous Substances	NPD	
Deleterious material	Negligible	SR 16:2016

Signed for and on behalf of Robinson Concrete by:

Scott Robinson

Director

Place & date of issue:

86 Cumber Rd, Claudy 11-02-2025
